

Kit Contents

REVISIONS			
REV	DESCRIPTION	DATE	APPROVED
A	INITIAL RELEASE PER ECO 18-23910	06/27/18	K.DUBROWN
B	RENAME PER ECO 18-24516	11/08/18	K.DUBROWN

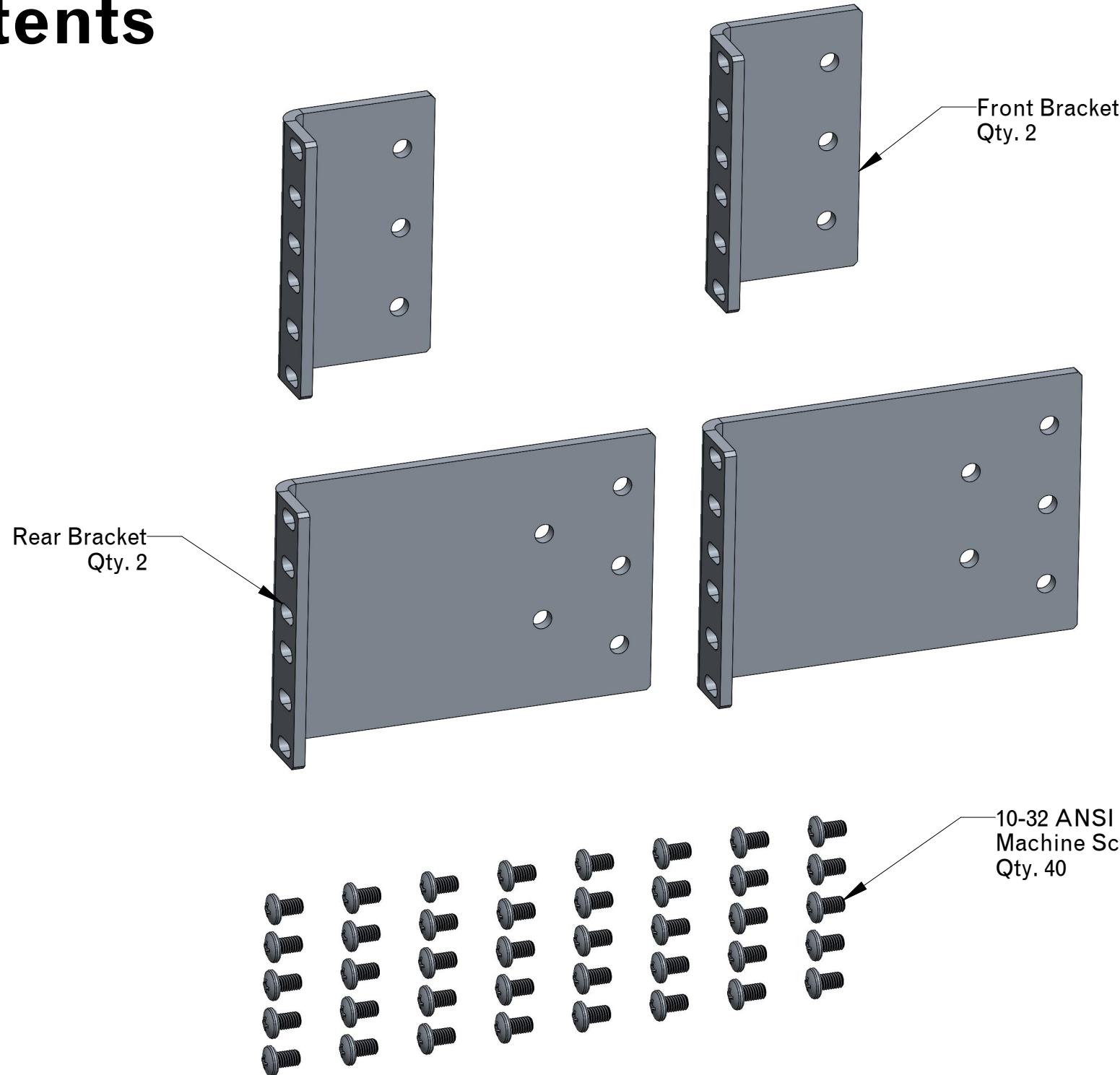

INCLUDED IN KIT:
 1. FRONT BRACKET, QTY: 2
 2. REAR BRACKET, QTY: 2
 3. 18-8 SS PAN HEAD, ANSI TYPE I CROSS RECESS MACHINE SCREW 10-32 THREAD 5/16" LENGTH, QTY: 40

NOTES:
 1-1: KIT DESIGNED FOR COMPATIBILITY WITH EIA/ECA-310 19 INCH RACKS, BOTH WIDE AND UNIVERSAL SPACING. KIT ALSO COMPATIBLE WITH IEC 60297-3-100 482.6 mm (19 in) SERIES RACKS, TYPE I AND TYPE II.
 1-2: USE 30 in-lb TORQUE FOR ALL HARDWARE INSTALLATION
 1-3: REFERENCE SYNQOR SPECIFICATION: 554-1000027, 554-1000028
 1-4: WEIGHT: 2.3 lbs (1.04 kg)

TOLERANCES: Unless otherwise specified: All dimensions in inches .X +/- .025 .XX +/- .010 .XXX +/- .005 Angles +/- 1°						155 Swanson Road Boxborough, MA 01719-1316	
				SHELTER GRADE UPS HARD MOUNT KIT			
SOURCE: PRO/E COTS_SYN-9051_STEP2							
SIZE	DATE	DWG. NO.		REV			
B	NOV-08-18	SYN-9051		B			
SCALE: 0.650		DRAWN: KJD		CHECK:		SHEET 1 of 5	

1

2

3

4

A

A

B

B

C

C

D

D

1

2

3

4

Hard Mount Bracket - Chassis Installation Diagram

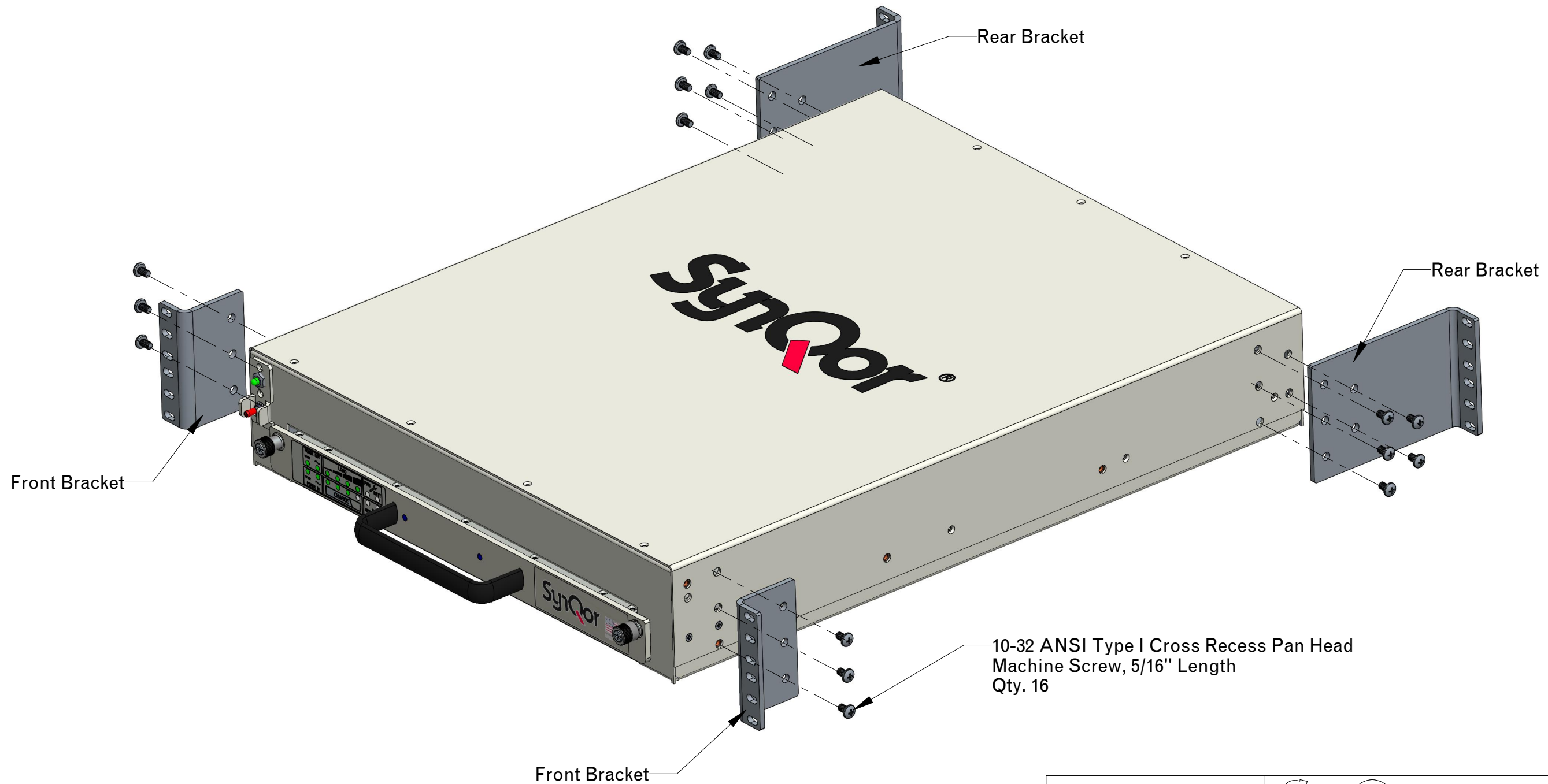

<p>TOLERANCES: Unless otherwise specified: All dimensions in inches .X +/- .025 .XX +/- .010 .XXX +/- .005 Angles +/- 1°</p> <p>Third Angle Projection</p> <p>THIS DRAWING IS THE PROPERTY OF SYNQOR LLC. It is not to be reproduced or copied, in whole or in part, or used for furnishing information to others, or for any purpose detrimental to the interests of SynQor. The information shown herein may be protected by patents owned or controlled by SynQor.</p>			155 Swanson Road Boxborough, MA 01719-1316	
	SHELTER GRADE UPS HARD MOUNT KIT			
	SOURCE: PRO/E COTS SYN-9051			
	SIZE B	DATE NOV-08-18	DWG. NO. SYN-9051	REV B
SCALE: 0.350		DRAWN: KJD	CHECK:	SHEET 2 of 5

Bracket- Rack Mounting Diagram

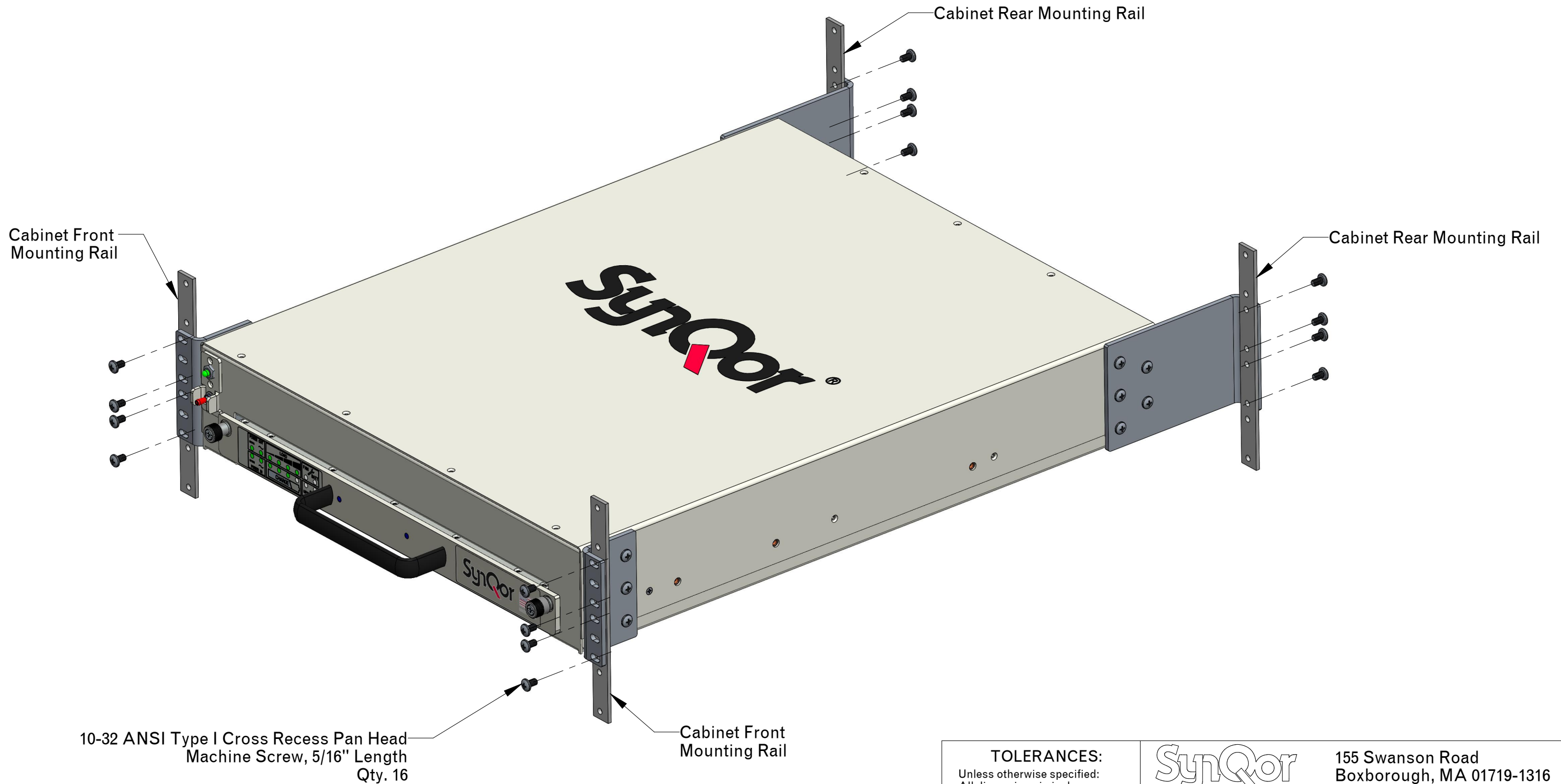

NOTES:
 3-1: A MINIMUM OF 4 MOUNTING SCREWS ARE REQUIRED PER BRACKET FOR SHOCK AND VIBRATION EXPOSURE. ADDITIONAL SCREWS INCLUDED IN KIT MAY BE INSTALLED AT CUSTOMER DISCRETION FOR ADDED MARGIN.

TOLERANCES: Unless otherwise specified: All dimensions in inches .X +/- .025 .XX +/- .010 .XXX +/- .005 Angles +/- 1°						155 Swanson Road Boxborough, MA 01719-1316	
				SHELTER GRADE UPS HARD MOUNT KIT			
SOURCE: PRO/E COTS SYN-9051_STEP0							
SIZE	DATE	DWG. NO.		REV			
B	NOV-08-18	SYN-9051		B			
SCALE: 0.250		DRAWN: KJD		CHECK:		SHEET 3 of 5	

THIS DRAWING IS THE PROPERTY OF SYNQOR LLC. It is not to be reproduced or copied, in whole or in part, or used for furnishing information to others, or for any purpose detrimental to the interests of SynQor. The information shown herein may be protected by patents owned or controlled by SynQor.

1 2 3 4

NOTES:
 4-1: MATERIAL: ANSI 1080 COLD ROLL STEEL
 4-2: FINISH: ZINC AND CLEAR CHROMATE

A

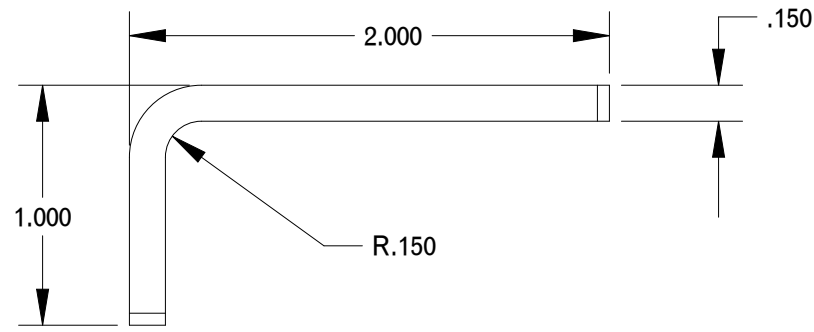

B

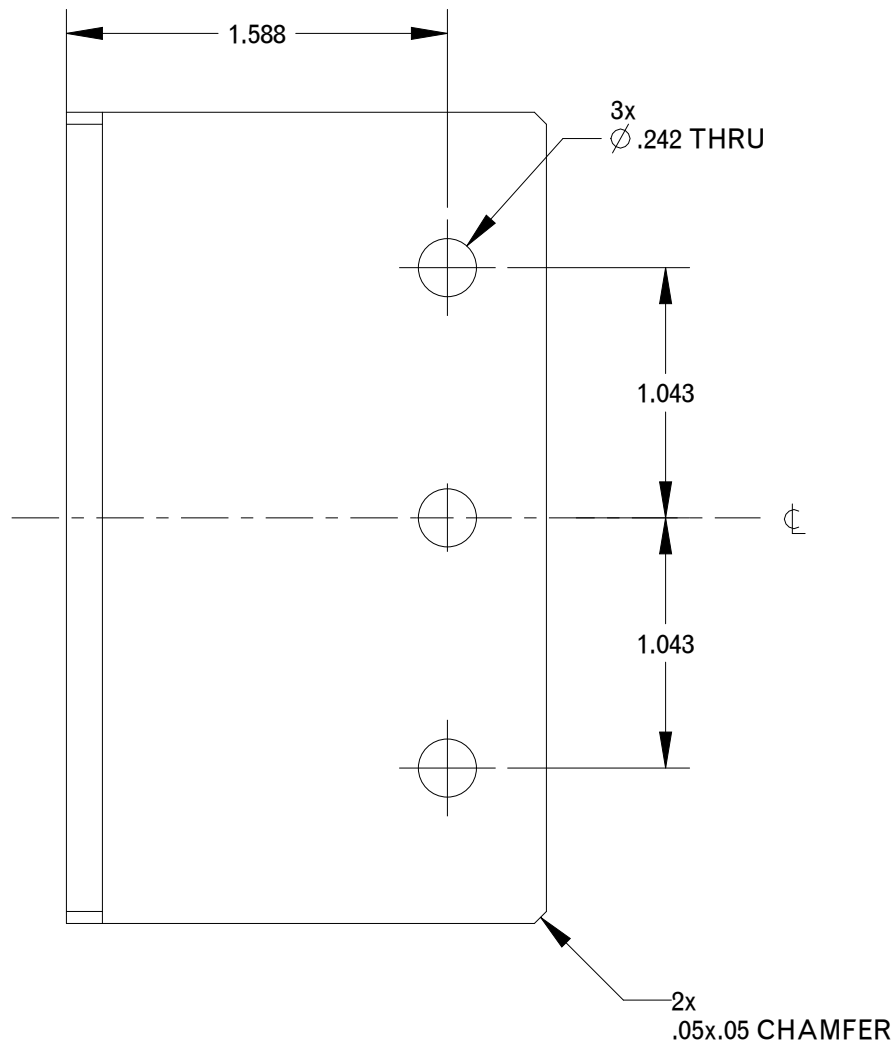

C

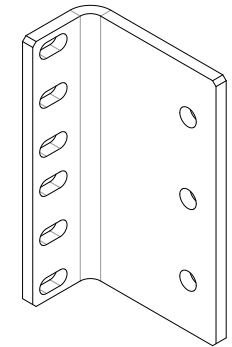
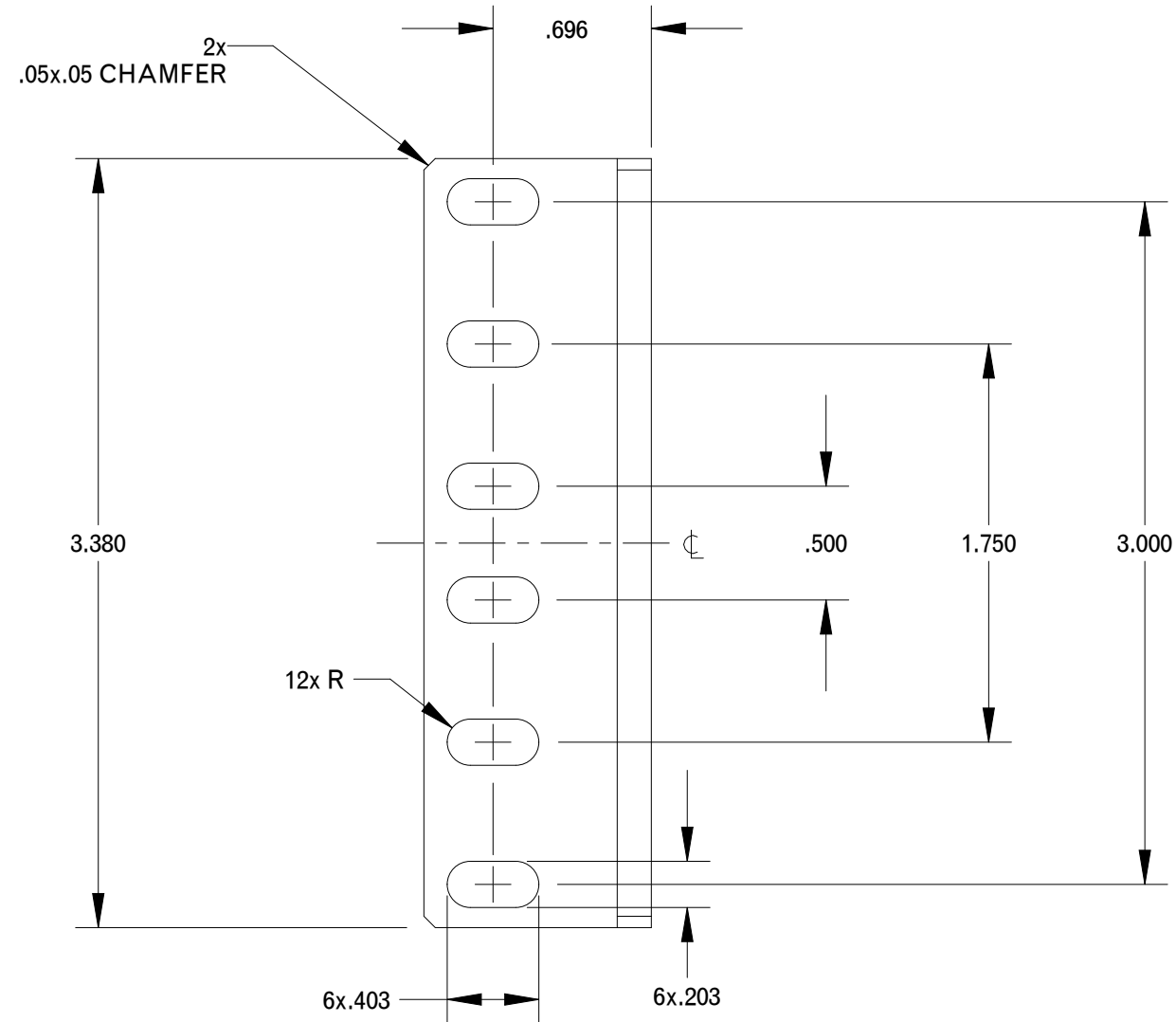

SCALE 0.500

D

<p>TOLERANCES: Unless otherwise specified: All dimensions in inches .X +/- .025 .XX +/- .010 .XXX +/- .005 Angles +/- 1°</p>			<p>SynQor 155 Swanson Road Boxborough, MA 01719-1316</p>	
	<p>SHELTER GRADE UPS HARD MOUNT KIT</p>			
<p>SOURCE: PRO/E COTS SYN-9051_STEP2</p>				
<p>SIZE B</p>	<p>DATE NOV-08-18</p>	<p>DWG. NO. SYN-9051</p>	<p>REV B</p>	
<p>SCALE: 1.250</p>		<p>DRAWN: KJD</p>	<p>CHECK:</p>	<p>SHEET 4 of 5</p>

1 2 3 4

1 2 3 4

NOTES:
 5-1: MATERIAL: ANSI 1080 COLD ROLL STEEL
 5-2: FINISH: ZINC AND CLEAR CHROMATE

A

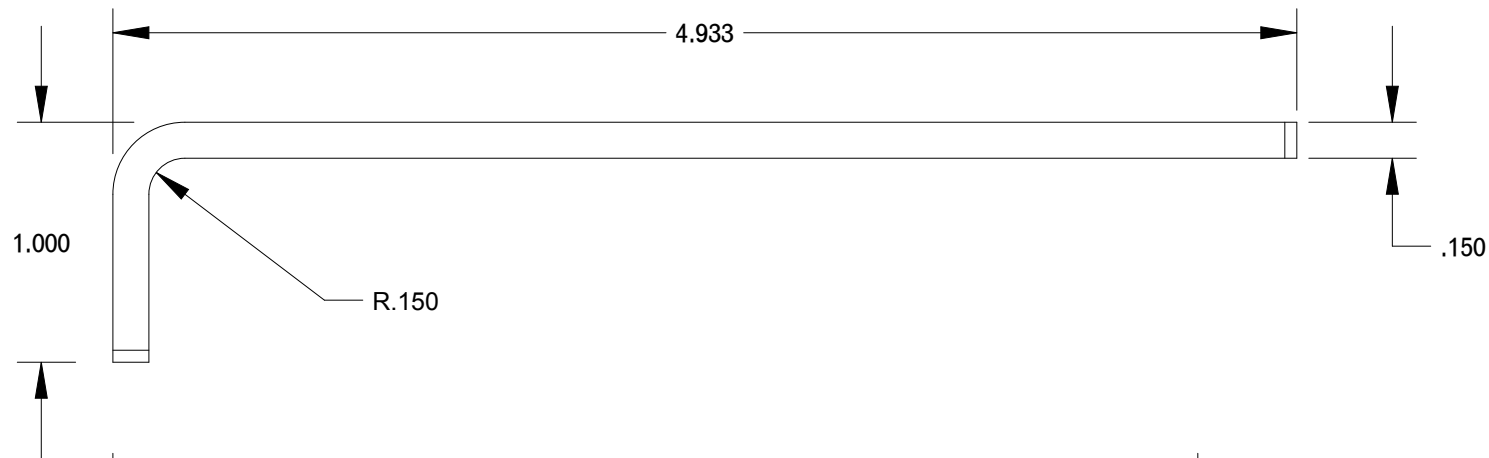

B

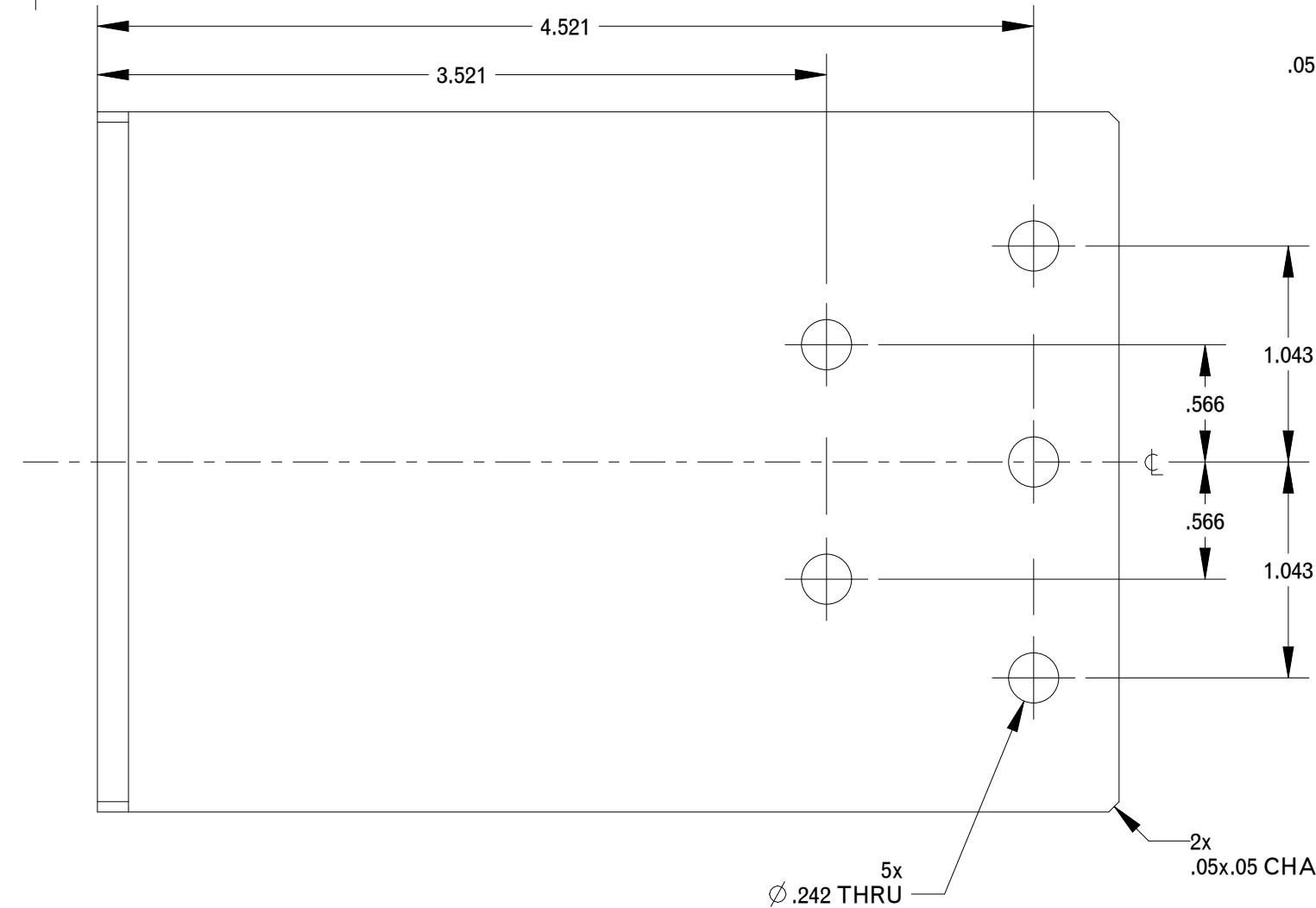

C

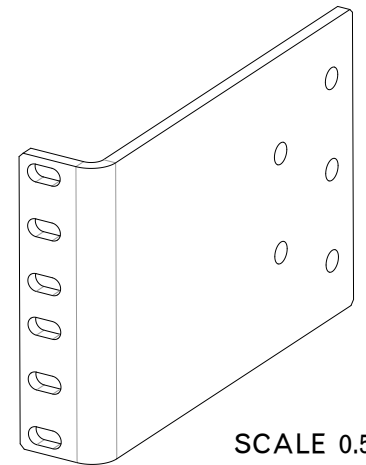
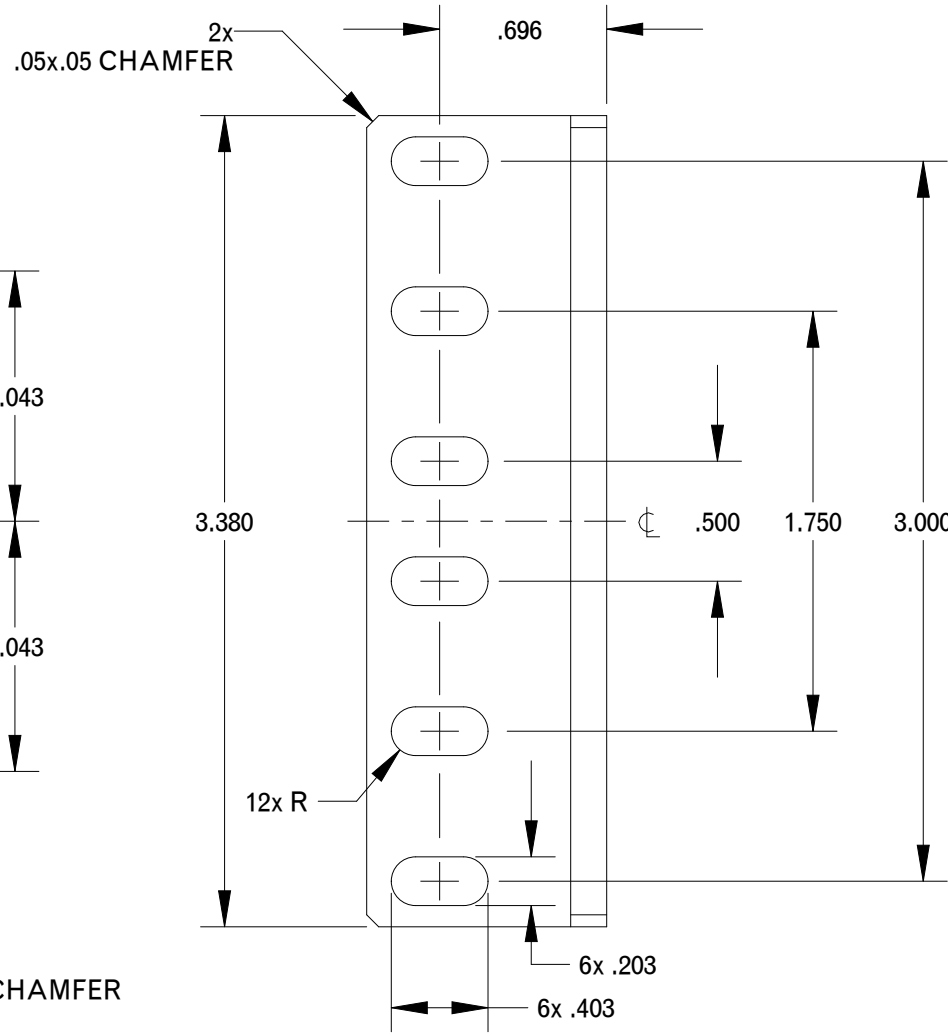

SCALE 0.500

D

<p>TOLERANCES: Unless otherwise specified: All dimensions in inches .X +/- .025 .XX +/- .010 .XXX +/- .005 Angles +/- 1°</p> <p>Third Angle Projection</p> <p>THIS DRAWING IS THE PROPERTY OF SYNQOR LLC. It is not to be reproduced or copied, in whole or in part, or used for furnishing information to others, or for any purpose detrimental to the interests of SynQor. The information shown herein may be protected by patents owned or controlled by SynQor.</p>			155 Swanson Road Boxborough, MA 01719-1316	
	<p>SHELTER GRADE UPS HARD MOUNT KIT</p>			
	SOURCE: PRO/E 554-1000027			
	SIZE B	DATE NOV-08-18	DWG. NO. SYN-9051	REV B
SCALE: 1.250		DRAWN: KJD	CHECK:	SHEET 5 of 5

1

2

3

4